

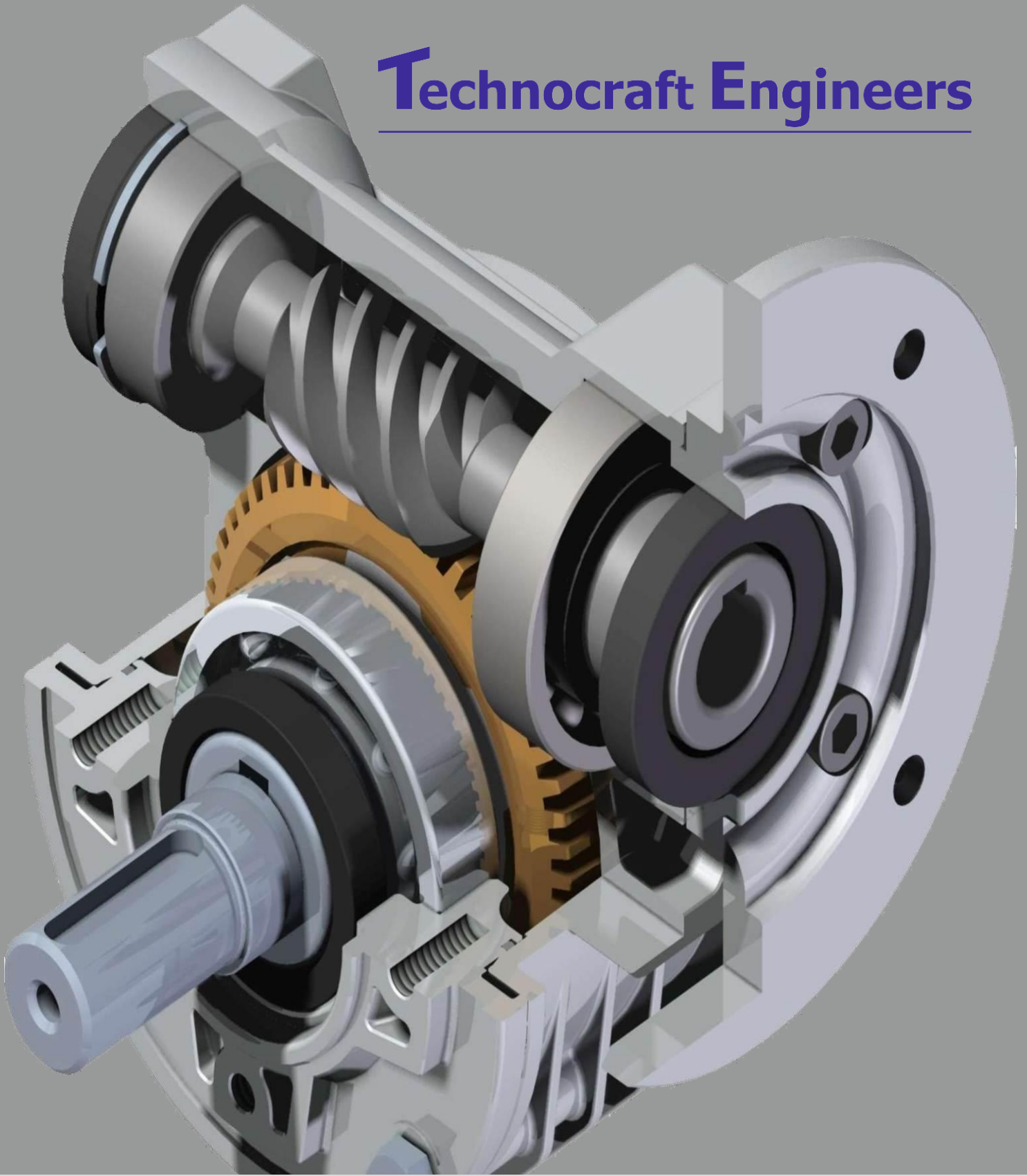

# Technocraft Engineers



## Technocraft Engineers

Designers & Manufacturers of  
Custom Built Geared Units, Linear Motions,  
Automation Systems & Special Purpose machines

## ABOUT US

We are pleased to introduce ourselves as Manufacturers and Concept Development Engineers along with consultancy & Design.

The firm is headed by Mr.Ravindra Shembekar, Graduate in Mechanical Engineering from VJTI, Mumbai with 25 years experience in various industries.

We have specialized ourselves in Design and Manufacturing of Gear Boxes and Geared Units by using theories that have been approved by Indian Institute of Technology as well as many industries like Larsen and Toubro Ltd. By virtue of these we are able to decide the parameters most economically depending upon the application.

We have with us most advanced software like Solid Edge by virtue of which we can Make "Three dimensional models", solid modeling, animation and other new techniques.

### We Offer our services for following fields:-

Manufacturing of Special Purpose Precision Gear Boxes of any desired ratio and size such as Spur Gear Boxes, Helical Gear Boxes, Worm Gear Box, Bevel Gear Boxes. Design, Engineering and manufacturing of Custom-built Fractional Horse Power Geared Motors, being used as import substitutes by many Original Equipment Manufacturers (OEM's)



Design, Engineering and manufacturing of Rotary Mechanisms involving Gear Boxes, involving Lead Screw Mechanisms, Geneva Mechanism and many other Kinematics Linkages.

Our SME Registered firm having infrastructure which includes following:-  
A full-fledged manufacturing/assembly shop of approx. 700 sq. ft. at Wagle Estate, Thane, Quality machinery including Kirloskar and reputed make Lathes, Various measuring and testing equipment /jigs/fixtures.

We have with us a separate dedicated shop where in we have installed LMW Smart urn CNC lathe along with Capstan lathe and a Metal Cutting Band Saw Machine. .We are catering to export oriented requirements by way of doing Job work.

A separate gear hobbing/cutting shop of approx. 350 sq. ft at Wagle Estate, Thane.

**We have world class MIKRON Universal Gear Hobbing Machine best of its kind.**

**Design and drafting facility including Computers, Printers with AutoCAD compatibility Three Dimensional Solid Modeling software - Solid Edge.**

## SERVICES

We conduct technical audit and also Finite Element Analysis at component level for entire project.

We offer our consultancy in the field of Gear Design and Manufacturing gears and gear boxes.

We offer commissioning of systems provided by us at site.

The projects or Products mentioned in our list Rod Gearing Mechanism, Remote Operation of Valves are undertaken on complete installation basis.

We ensure satisfactory trials at Site.

We have customized Gear Design software and also we have relevant data form ASTM E / PSG and many other authorized institutions. We have licensed version of Autocad as well as Solid Edge Three Dimensional modelling software.

Besides we have a team of engineers who assist us in this regards, fully equipped with latest software and technologies.

When we undertake a turnkey project, we design and check all components as per up to date design standards. We also have expertise to vary the particular parameters as per the requirement of application.

We undertake reverse engineering projects when a sample is provided to us and we can reproduce the exact replica of the same with same operating standard.

### **Technical Audit for Safety in Design for Screw Gate Mechanism used in Irrigation Dam Project**

We have conducted Technical Audit for supplies at Hetawane Dam as per stipulations from State Government.

Finite element analysis was conducted at our end for each vital component used in the system and report submitted by us.

Client: CIDCO at Hetawane, New Mumbai.

## FOLLOWING ARE THE PRODUCTS THAT WE OFFER

- A}Bevel Gearboxes For Pharma Machinery
- B}Bevel Gearboxes with 4 Output Shaft.
- C}Geneva Gearbox
- D}Screw Jacks
- E}Engine Overhauling Stand
- F}Rod Gearing Mechanism For Damage Control Simulator.
- G}Special Purpose Laboratory Machine
- H}Bevel Gearbox For Remote Operation Of Valves
- I}Gearbox For Lighting Grids In Film Studios
- J}Welding Automation
- K}Drive Unit For Coil Winding Plant
- L) Fractional Horse Power Geared Electric Motors
- M)Lifting Machine for BARC
- N)Heli Bevel Worm Gearbox



### **A) Bevel Gearboxes for Pharmaceutical Machinery**

We are using High Precision Spiral Bevel Gears With Ground Teeth, imported from Japan.

Specifications as follows,

Precision grade JIS B 1704: 1978 grade 1

Gear teeth Gleason

Pressure angle 20 °

Helix angle 35 °

Material SCM415

Heat treatment Carburizing

Tooth hardness 55 - 60HRC

Gear ratio 1

Screw offset (L) half of hub width (H)

The specifications are as follows:

1. Right Angle Bevel Gearbox 1:1
2. Power of the connected Motor: Operating RPM: In the range of 500 RPM to 2000 RPM
3. Material of Construction: All the external surfaces Fabricated out of SS - 316L Grade with TC
4. External shape: to be inline with GMP guidelines (e.g there should not be any External

crevices. Should be smooth. So that the product, which is pharmaceutical easily powder, slides over and falls down)

5. All external surfaces should be washable and sterilizable (by steam)
6. Exposed plastic/rubber surfaces (for example the seals) of food grade/FDA approved. Viton seals and Food quality grease used.
7. Self-sufficient in terms of lifetime lubrication
8. No oil spills/leakages

## SALIENT FEATURES:

1. HOUSING, SHAFTS MATERIAL SS 316-L AS PER GMP GUIDELINES
2. APPROPRIATE AND BEST QUALITY BEARINGS
3. HIGH PRECISION SPIRAL BEVEL GEARS WITH TEETH GROUND IMPORTED FROM JAPAN ON ACCOUNT OF ACCURACY AND SPECIAL RAW MATERIAL SMALLER SIZE ENABLES COMPACT GEARBOX AND SMOOTH & NOISELESS OPERATION.
4. VITON SEALS USED
5. FOOD QUALITY GREASE USED

## DELUMPER

MODEL: TECHNOCRAFT 3020

The Bevel Gearbox is used for changing the orientation of rotation by 90 Degrees. The output is derived from combination of Motor and Worm Gearbox. Here speed is low however Torque to be transmitted is high. The Bevel Gearbox 1:1

The Requirement for DELUMPER is summarised as follows:

1. Right Angle Bevel Gearbox 1:1
2. Operating RPM: In the range of 30-60 RPM. Torque 500 NM TO 1000 NM.
3. Material of Construction: All the external surfaces Fabricated out of SS - 316L grade with TC
4. External shape: to be inline with GMP guidelines (e.g there should not be any external crevices. Should be smooth...so that the product, which is pharmaceutical powder, easily slides over and falls down)
5. All external surfaces should be washable and sterilizable (by steam)
6. Exposed plastic/rubber surfaces (for example the seals) of food grade/FDA approved. Viton seals and Food quality grease used.
7. Self-sufficient in terms of lifetime lubrication
8. No oil spills/leakages



## B) Bevel Gearboxes with 4 Output Shaft Special Purpose Gear Box with Self Locking Characteristic for Engine Mounting Trolley

The specifications are as follows:



1. This is a typical application where in synchronized motion transfer is required to operate different units simultaneously in a blister packing machine.
2. The concept was explained to us and we have engineered the solution.
3. The drive is 3HP servo motor with a worm gearbox reduction.
4. Teeth generated Bevel Gears with high accuracy and case hardened is used.
5. Least amount of backlash has been maintained.
6. There are One Input and 3 Output shafts in one plane and besides another shaft id extended downwards to give one more output.
7. SKF or equivalent make ball bearings are used.
8. Lubrication is appropriate grade Grease to avoid leakages

## C) Geneva GearBox

The specifications are as follows:

We have been manufacturing Special purpose Gearbox with Geneva mechanism to deliver Output Torque of 3.2 KN-Mt with 10 H.P. Motor, intermittently

This is a typical application used for intermittent motion in Grating manufacturing plant. The temporary dwell period is used for electro forged welding of Gratings on a conveyor. This is an import substitute continuous duty application.

- ❖ INPUT 10 HP 1440 RPM RATIO; WORM REDUCTION 49:1
- ❖ TIME OF INDEXING - 0.8276 SECONDS; RESTING TIME - 1.2414 SECONDS
- ❖ MAX. OUTPUT TORQUE - 3200 N-MT.; lubrication:- OIL

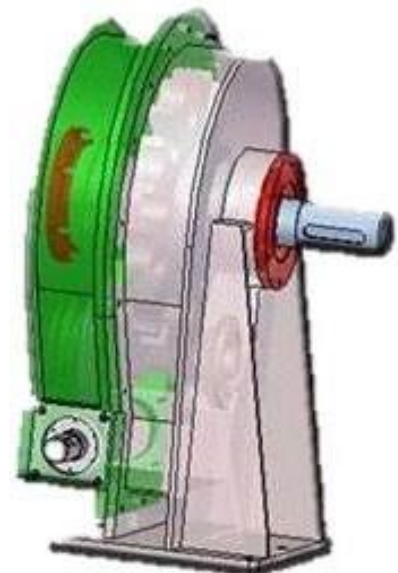

## D) Screw Jack

The specifications are as follows:

We design tailor made applications involving Lead Screw Mechanisms One such application refers to PORTAL BRIDGE at NCPA Theatre where in 5 Tonne weighing Portal Bridge is moved vertically Upwards and Downwards by means of Two Screws with Motor at the Centre.

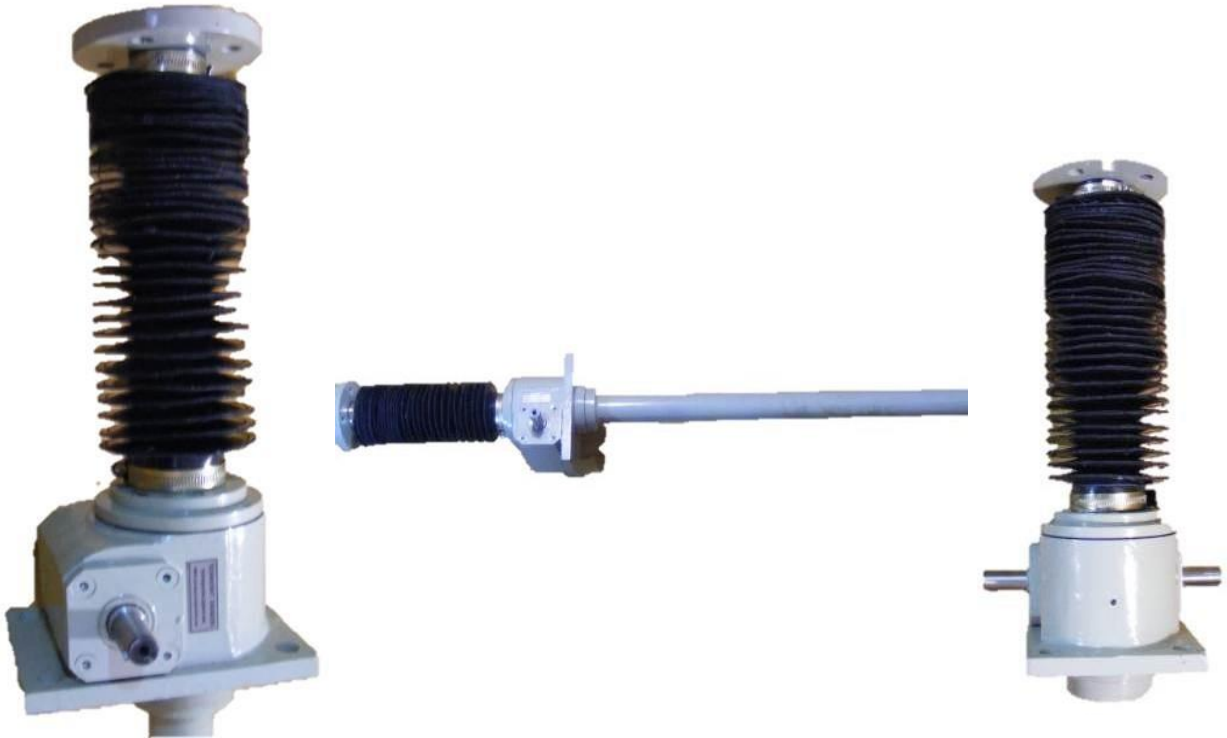

In case of Bevel jacks we use Teeth generated case hardened Bevel Gears.

1. We are specialized in designing and manufacturing special purpose or custom built screw applications.
2. The picture shows a typical screw jack designed to lift 2.5Tonnes for some export application.
3. Bellows used for protection from dust and atmospheric corrosion.
4. Precision Trapezoidal screw M30x7P, Taiwan make is used. We also manufacture Screw Jacks of different capacities with imported Trapezoidal Screws



## E) Engine Overhauling Stand

The specifications are as follows:

1. This is a Hand operated Gear Box, with extended shaft.
2. Automobile engine to be overhauled is mounted on the shaft by means of special adapters fitted either at Bell Housing or at Exhaust manifold.
3. This facilitates easy assembly of parts on the engine body.
4. Used at automobile dealers/ Service stations.
5. This is a Service Tool
6. End User: Fiat India Ltd. TATA MOTORS, MAHINDRA & MAHINDRA LTD.
7. Besides we have also developed various Service Tools for the similar applications.

## F) Rod Gearing Mechanism for Damage Control Simulator.

The specifications are as follows:

From staff control room of the simulator, flood valves and drain valves are operated by means of our Rod gearing mechanism. Universal mounting type specially designed bevel gear box units are typically used to transmit the motion from staff control room up to the valves situated at the base of the simulator at various locations. This facilitates simulation of sinking conditions and Naval staff is trained how to cope up with the situation.

The project was handled for Electro pneumatics and Hydraulic India Ltd, who in turn have supplied the vessel to Indian Navy.



## G) Special Purpose Laboratory Machine

The specifications are as follows:

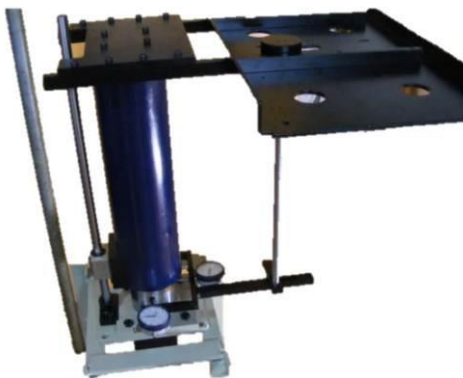

We have designed a special purpose machine used for Laboratory application; A horizontal platform weighing around 25 KG is lifted and lowered through a distance of 300mm.

We have used telescopic sliding mechanism with appropriate Lead screw and Box Nut with AC Geared Motor as drive. Use of Tie rods or Guide Rod is eliminated. Linear Speed is 0.25 mtrs/min.



## H) Bevel Gearbox for Remote Operation of Valves in a commercial ship

We have handled this project for Shipbuilding Division, Larsen and Toubro Ltd, Hazira Yard.

We have designed and manufactured system comprising of special purpose bevel gearbox to operate various valves from remote locations for the purpose of convenience of operations.

We have used bevel gearboxes for change in direction of rotations besides Rods, Pedestal Bearings and Universal Couplings are used.

Small compact bevel gearboxes with precise teeth generated Bevel Gears used inside are developed by us for this application.

We have even provided Bonnet Assemblies with asbestos free Gland Seals at appropriate Locations.



We have successfully completed a prestigious project for Shipbuilding Department Larsen and Toubro Ltd. Hazira works.

We have offered complete solution for Remote Operation of Valves located at inconvenient locations inside a Ship. We have also carried out commissioning at site (Ship).

The project was completed in record time period and up to the mark with remarkable fine operations of valves at various locations along with providing asbestos free gland packing with meticulous planning. It comprises of small Bevel Gearboxes, Rods, Universal Couplings and pedestal Bearings.

## I) Gearbox For Lighting Grids In Film Studios

Special Purpose Hoist Mechanisms used in Television and other Studios.



We have designed and developed Special Heli Worm Gearbox with Self Locking characteristics to lift and lower Lighting Grid ( 200 Kg to 2.5 Tonnes) by means of Ropes and Rope Drums.

This Motorized Lighting Grid is being used to install Lights along with service persons to cover desired area for Lighting for Film Shoots. We have also developed self climbing hoists for lighter applications.

1. Motorized Gear Box with Self Locking Characteristic along with Rope winding mechanisms with different capacities have been used for handling

2. Lighting Grids and other equipment's used for Photography and Shooting.
3. This facilitates easy adjustments as per the requirement.

## J) Welding Automation

We have supplied special purpose welding automation projects for Larsen and Toubro Ltd Powai, Mumbai works. We One such project has been elaborated as follows,

- This was a first of its kind activity in the world executed for L&T and in turn for the final customer NPCIL, on their KGS 3 Atomic Reactor at Kaiga - Karnataka state.

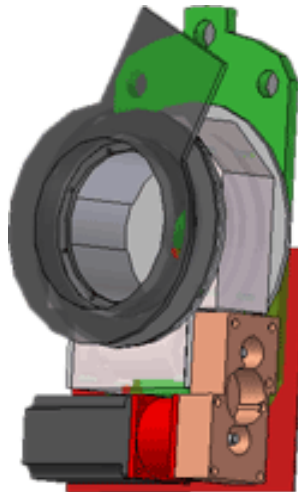

- The task involved was to automate the grinding and welding
- Operation on a Weld joint in a live Atomic Reactor. The critical
- part of the activity was to execute grinding and welding in an
- ID of 145 mm from a distance of 2.5 meters making use of Cameras for vision. The entire design of drive system, (consisting of planetary gear box, DC Motors, AC servo Motors & all related controllers etc.) manufacturing of the system components & trials was the scope taken up and executed successfully

## **K) Drive Unit For Coil Winding Plant**

**Complete Drive System with Self Locking Characteristic for rotating entire Rotor Assembly while inserting wound coils.**

1. Application Automation of Winding process of Rotors for 15 KW and above Generators.
2. Client: Siemens India Ltd. Kalwa Plant.



## **L) OTHER PROJECTS HANDLED**

**1} Complete Transmission system for the vertical movement of 10 ton Platform of 200 Ton stamping press for pressing of Transformer Stampings,  
Client: ABB, Baroda**

We have designed and manufactured complete transmission system for Vertical movement of a 200 Tonne capacity Hydraulic press. The system comprise of Four 150 dia Lead screws (1 TPI or 25mm Pitch), 4nos Box Nuts rotated synchronously by Hollow shaft Worm Gearboxes, Bevel gearboxes and finally by 12.5 HP electric motor at the canter.

**2}Long shaft synchronous operation for Portal Bridge for Stages as well as Geared Motors for vertical movement of curtains, known as Contour Curtain.**

We had successfully completed project for Vertical movement of Contour Curtain inside an auditorium. Also we had designed complete system for vertical movement of Portal bridge weighing 5tonnes.

- Application: Movement of vertical movement of stage equipment used in Drama,
- Client: NCPA (Tata Theatre) at Nariman Point, Mumbai.

## M) Lifting Machine for BARC

We have designed manufactured and supplied Special Purpose Motorized Lift Mechanisms for nuclear material handling purpose inside Glove Box.

### SALIENT FEATURES:

- 1} Machine using world class technology Linear Guides and Ground Trapezoidal Lead Screw M20x4P (International Brand) Hiwin Make (Model 15CC) Rails and L.M. Guides Two Rails and Four Guides. Imported Lead Screw Trapezoidal Threads M20x4P, Material EN-8 Electro less Nickel Plating (ENP)
- 2} Minimum Friction and smooth operation with High efficiency.



- 3} Requirement of Power - 90 Watts, 230 VAC, Single Phase, 1440/140 RPM, Flange Mounted Worm Geared Motor.  
Weight for movement considered 50 Kg. Linear Speed - 0.6 Mtrs/Min.
- 4} Guide Base Frame Material SS-304
- 5} Lift - 330mm Upward Downward Movement  
Positional Accuracy +/- 0.2
- 6} Other than Lead Screw and Rails entire components in SS-304
- 7} SS Sheet Metal Covers provided to enclose the mechanism
- 8} Sturdy Design and construction. Easy to dismantle and re assemble.

## N) HELI-BEVEL-WORM GEARBOX

### REQUIREMENT:

The Customer required 3-4 Ratio but *Self Locking* characteristic.

This was used by one reputed Defense Equipment manufacturer based in Dubai.

### SALIENT FEATURES:

1} REDUCTION RATIO - 3.43

A} FIRST STAGE - HELICAL (STEP UP) 4.75

B} SECOND STAGE - BEVEL (STEP UP) 1.84

C} THIRD STAGE - WORM REDUCTION 30 WITH SELF LOCKING

D} MOTOR COUPLED AT WORM



Manual Input and Motorized Overdrive provided at Worm with Inline Geared Motor.

WE HAVE SELECTED BLDC (BRUSHLESS DC MOTOR 150W, 24VDC WITH DRIVE) 3000 RPM WITH 5:1 HELICAL GEARBOX 520 RPM AT OUTPUT GEARED MOTOR OUTPUT TORQUE 2.1 NM AT 520 RPM

ALUMINIUM HOUSING  
BEVEL TEETH GENERATED  
THREAD GROUND WORM  
PHOSPHOR BRONZE WHEEL  
INPUT 8" WHEEL - SQU. 12  
OUTPUT - HOLLOW ID 25  
6 NOS M8x15 HOLES FOR MOUNTING



## Current Project:

We have been manufacturing precision small gearboxes to be used for FHP Geared electric Motors for last 25 years. These gearboxes are import substitutes.

This year we have started supplying Fractional Horse Power AC as well as PMDC GEARED ELECTRIC MOTORS. We have a wide range of gearboxes like Helical, worm and also Double reduction worm Gearboxes to cater to requirements of various Original Equipment Manufacturers.

Thus we have already entered into market as Geared Motor Manufacturers and we are getting good response from machine manufacturers.

Following are the photographs of some of standard Geared Motors manufactured by us.



### ➤ Helical Geared Motor:

Face Mounted Inline Helical Gearbox rated for 60 Kg-Cm or 6 NM Torque with noiseless operation in combination with AC or PMDC Motor can be supplied.



### ➤ Hollow Shaft Geared Motor:

Flange Mounted Worm Gearbox rated for 150KG-CM or 15 NM Torque with Hollow Output shaft Dia 17mm in combination with AC or PMDC Motor can be supplied as per requirement with various Output Speeds



**Bevel Gearboxes  
for Pharmaceutical Machinery**



**Bevel Gearboxes  
with 4 Output Shaft**



**Screw Jack**



**Special Purpose  
Laboratory Machine**



**Gearbox For Lighting  
Grids In Film Studios**



**Helical Geared Motor**



**Hollow Shaft  
Geared Motor**



**HELI-BEVEL  
WORM GEARBOX**

# Technocraft Engineers

---

Designers & Manufacturers of  
Custom Built Geared Units, Linear Motions,  
Automation Systems & Special Purpose machines



**Technocraft Engineers**

---

B-19, MIDC Flatted Factory, Near Check Naka, LBS Road, WIE,  
Thane - 400 604. INDIA. Tel. : +91 22 2580 0065 Fax : +91 22 2583 3872  
Email : [technogearbox@gmail.com](mailto:technogearbox@gmail.com); [info@specialpurposegearboxes.com](mailto:info@specialpurposegearboxes.com)  
Website : [www.specialpurposegearboxes.com](http://www.specialpurposegearboxes.com)